

JPT

Manufacturers of Fine Quality
Diamond Dressing Tools, PCD Tools
(www.jainprecisiontools.com)

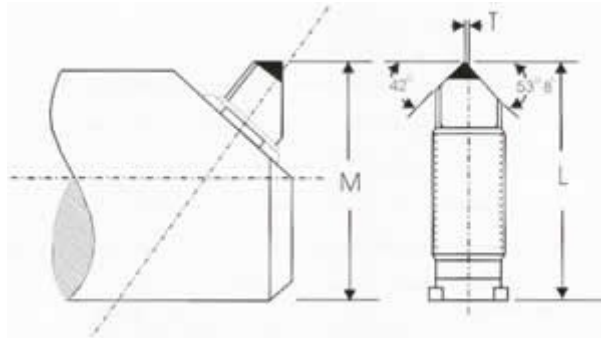

T= Tool Point Offset is on the Right of centre of cartridge

Note: * All dimension in mm, * 12° top rake can be used Alluminium. * All specifications subject to change without notice. * All left cartidges will have same tool Geometry. * Ordering please specify PCD or CBN

Microbore No.	M. Min Bore	Length	T
M1 A2	16.1	14.2	0.4
M1 B2	13.4	11.4	0.4
M2 A2	21.1	19.9	0.4
M2 B2	18.8	16.8	0.4
M3 A2	26.1	25.5	0.8
M3 B2	23.1	21.5	0.8
M5 A2	41.4	39.8	1.2
M5 B2	35.8	33.4	1.2
M7 A2	58.8	55.7	1.6
M7 B2	53.3	49.3	1.6

Jain Precision Tools

Regd. Office & Factory: J-14,MIDC Area , Chikalthana, Aurangabad -431006 (M.S). India

Phone No: +91-240-2482841, 2485643, 2470029,2337176,2330757 Mobile : 98220 43746

Fax No: +91-240-2474491

Email : jaintools@rediffmail.com , reponse@jainprecisiontools.com .

Website :www.jainprecisiontools.com